

Heckert X40/X45

Five-axis complete machining

Maximum productivity, minimum footprint



Contents

Thermal symmetry

Precision is a question of symmetry

Philosophies are nebulous concepts based on assumptions. Values, on the other hand, represent a conscious decision to invest the daily effort that goes into upholding them. And it's this effort that always pays off in the end. Starrag recommits to its values on a day-to-day basis.

Each of our machines is built from the ground up to embody measurable precision, based on our rock-solid thermo-symmetrical design concept. This is no philosophy – these are values which are measurable for every single component of our machines. And Starrag's commitment to values can pay off for you too.

04

Basic
machine

06

Customer
needs

08

Features of
Heckert X40

10

Technical data for
Heckert X40

12

Features of
Heckert X45

14

Technical data for
Heckert X45

16

Tool magazines
and spindles

18

User case
study

20

Human-machine
interface

22

Automation

Large workspace, small footprint

These five-axis horizontal machining centres are space-saving miracles, but they remain true to our stringent quality standards in every respect. They guarantee maximum precision for your work processes thanks to our guiding values of accuracy and rigidity. These are values embodied by Heckert machining centres throughout their decades-long history on the market.

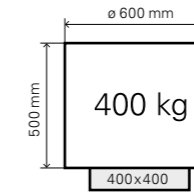

Heckert X40

X / Y / Z travel	mm	700 / 750 / 750
Machine length	mm	6,750
Machine width	mm	2,840
Toolholder		HSK-A63

Heckert X45

X / Y / Z travel	mm	700 / 750 / 750
Machine length	mm	6,750
Machine width	mm	2,960
Toolholder		HSK-A100

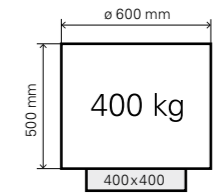

We safeguard your future

Our machines meet tomorrow's needs today. Protect your company's progress.

Profitability

Cost reduction

We want to reduce costs! ✓

We help you comprehensively. With our machines you optimize your investment and maintenance costs. What's more, you can sustainably reduce your unit costs thanks to the low space requirement and high energy efficiency.

Productivity

How can we increase our productivity? ✓

Two decisive approaches:

The high rigidity of our machines allows you to increase chip removal, which reduces your cutting time.

We keep the non-productive time – such as tool change, spindle speed-up, pallet changing and B-axis positioning – to a minimum, resulting in faster turnaround times and increased productivity.

Safety

Partnership

Time is money – how can we save both? ✓

Our aim is not only to equip you with the most precise machine tools on the market, but also to ensure this precision in the phases of consulting and project realization.

This guarantees tailor-made solutions in time.

Reliability

Stable processes without nasty surprises – is this possible? ✓

Of course. Even after years our machines work with high precision and thus minimize downtime.

This ensures the highest quality and productivity over decades.

Growth

Development

We want to think about the future today! ✓

Whatever the future holds: As a global corporation, Starrag bundles state-of-the-art know-how and thus develops future technologies for upcoming challenges.

Competitiveness

We will henceforth be able to flexibly continue to grow? ✓

Absolutely.

Thanks to modular machine groups, modules can be redesigned and replaced even after many years.

They remain state-of-the-art and above all: competitive.

Designed to your benefit

The basic modular concept of the new Heckert machining centres offers maximum efficiency even with a standard configuration. And that's no coincidence, since a consistent increase in added value for the customer was essential for the development of each individual assembly.



Column

Maximum productivity

- › Thermo-symmetrical design
- › High level of rigidity
- › Direct chip disposal, even for dry machining



Tool magazine

Less non-productive time

- › Up to 320 tools
- › Individually configurable
- › Ergonomic loading and unloading
- › Also with tool identification



Work spindle

A clear competitive edge

- › Up to 350 Nm torque
- › Up to 30,000 rpm
- › Extremely short speed-up time with HSK-A63



Fifth axis

Reliability in the manufacturing process

- › Unique level of stability thanks to bearings on both sides
- › Maximum accuracy thanks to thermal-symmetric design
- › Maximum dynamics in positioning mode and simultaneous operation
- › Excellent chip disposal



Pallet changer

More flexibility

- › 12.5 second pallet change time
- › Set-up during machining time
- › Automatic loading doors (option)



Workpiece carrier

Safe loading and unloading

- › 13-channel hydraulic clamping unit
- › Maximum precision for machine pallets
- › Individually adaptable

Footprint

Reduced investment costs

- › Footprint reduced by 38 %
- › Peripheral units are fully integrated



Heckert X40

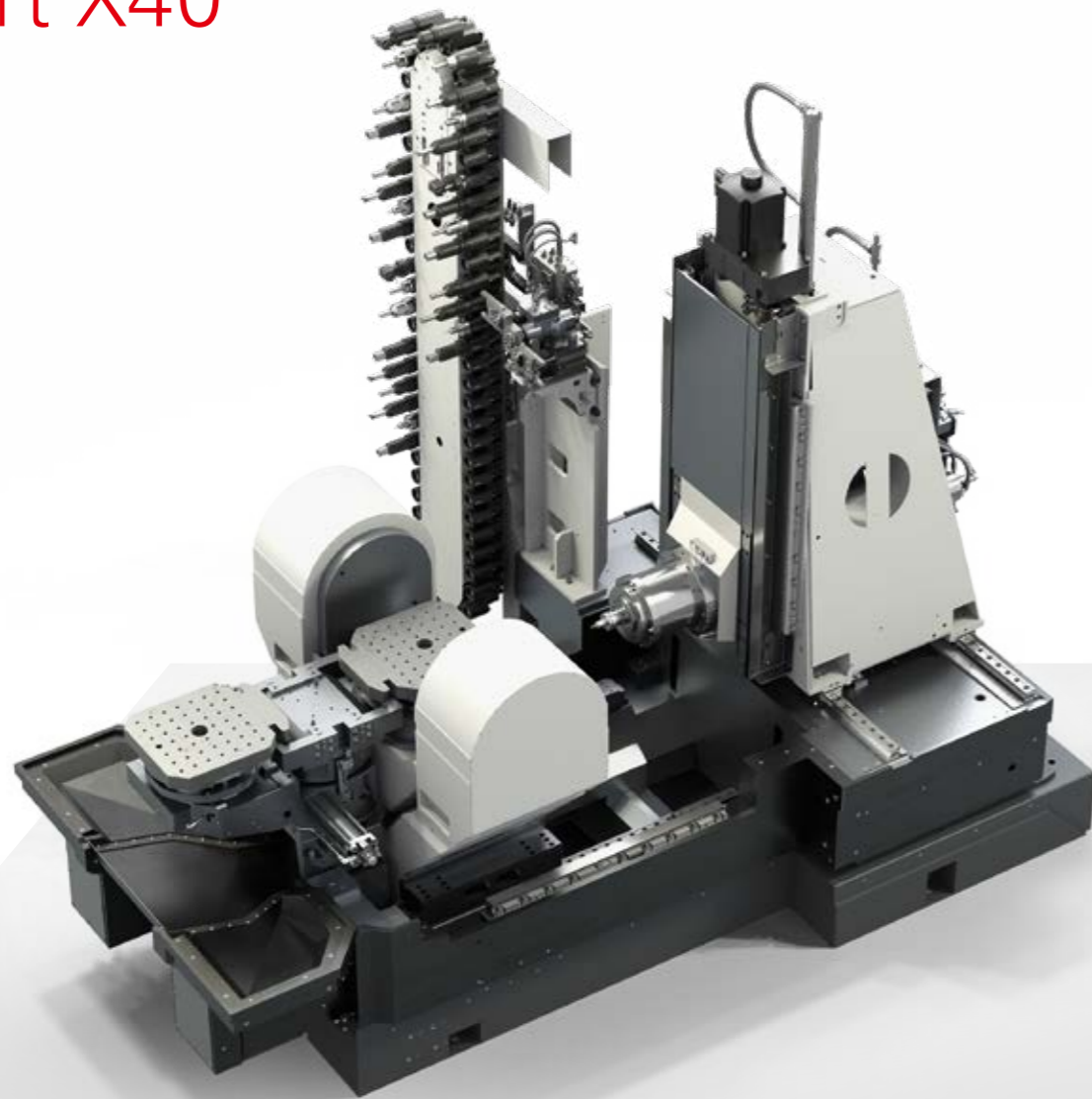

Technical data

		Heckert X40
Rapid traverse	m/min	80
X/ Y/ Z acceleration	m/s ²	8/11/10
Chip-to-chip time	s	3.2
Toolholder		HSK-A63 (SK, BT, CAT)
Max. tool length	mm	450
Max. tool width	mm	160
Time required to change pallets	s	12.5
Workpiece core contour	ø in mm	600
Loading mass	kg	400
Pallet dimension	mm	400x400 (400x500)
Machine length/width	mm	6,750/2,840

Heckert X40

For endurance runners and cool calculators

With a Heckert X40, you work with high dynamics in five axes and in one clamping position on five sides. In addition, you benefit permanently from the effective use of space and the high long-term accuracy. Do the math.



23%

Higher productivity

through complete machining in one clamping position, with reduced space requirement and highest performance.

Our machines grow with your tasks

You can benefit from the small footprint of our compact machining centres even at more demanding jobs. We have designed the relevant components for heavy-duty machining.



Work spindle and toolholder

Maximum productivity

- › Increased traction and form fit for maximum torques
- › 15,000 rpm
- › Extremely short speed-up time
- › With HSK-A100

Tool magazine

Less non-productive time

- › Up to 240 tools
- › Individually configurable
- › Ergonomic loading and unloading

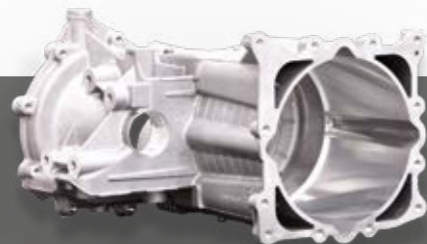

Heckert X45

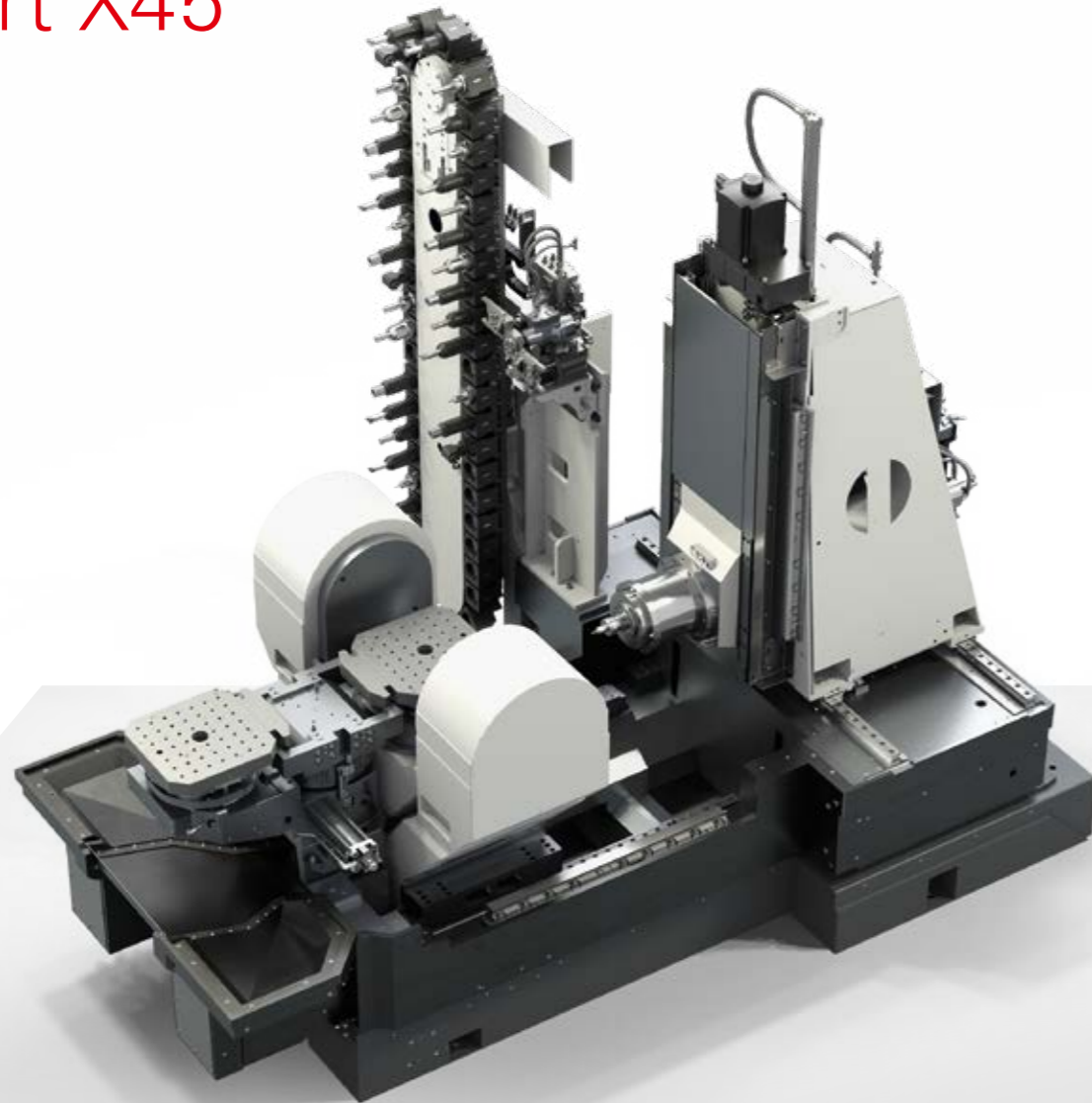

Technical data

		Heckert X45
Rapid traverse	m/min	80
X/ Y/ Z acceleration	m/s ²	8/11/8
Chip-to-chip time	s	3.8
Toolholder		HSK-A100
Max. tool length	mm	430
Max. tool width	mm	220
Time required to change pallets	s	12.5
Workpiece core contour	ø in mm	600
Loading mass	kg	400
Pallet dimension	mm	400x400 (400x500)
Machine length/width	mm	6,750/2,960



20%

Cost reduction

thanks to shorter processing time and increased process reliability with reduced space requirement.

Heckert X45

Precision ensures safety, especially under pressure

Thermo-symmetrical design, rigidity, optimum damping and a trunnion table pivot-mounted on both sides are the pillars for precise five-axis machining of tough materials. Pitmen around the world rely on it.

Productivity meets flexibility

Our diverse range of spindle and magazine options can be tailored to your individual requirements, for production processes that can handle whatever the future holds.

The new Heckert machining centres use a modular basic concept that can be extended to include a wide range of different assemblies. Each and every component has been redesigned and redeveloped to bring it into line with the state of the art. This means you can configure machining solutions that are tailored exactly to your needs, meeting the highest possible quality standards without sacrificing productivity.

When we design and integrate each of our assemblies, we draw on over 100 years of experience in machine tool construction. There can be no doubt in anyone's mind about our familiarity with the market and its demands. The same can be said about our reliability and standard of customer service, since these too are values that underpin our R&D work with a view to delivering consistent added value to our customers.

320

Heckert tool magazines

Heckert machining centres can be supplied with a factory-fitted tool magazine with up to 320 tools, according to your individual requirements. We design and build all of the magazines ourselves, since this is the only way to safeguard our customary high standards of quality and reliability. Thanks to our patented concept, the linear chain magazine is guaranteed to deliver the same dynamics as an individual tool chain.

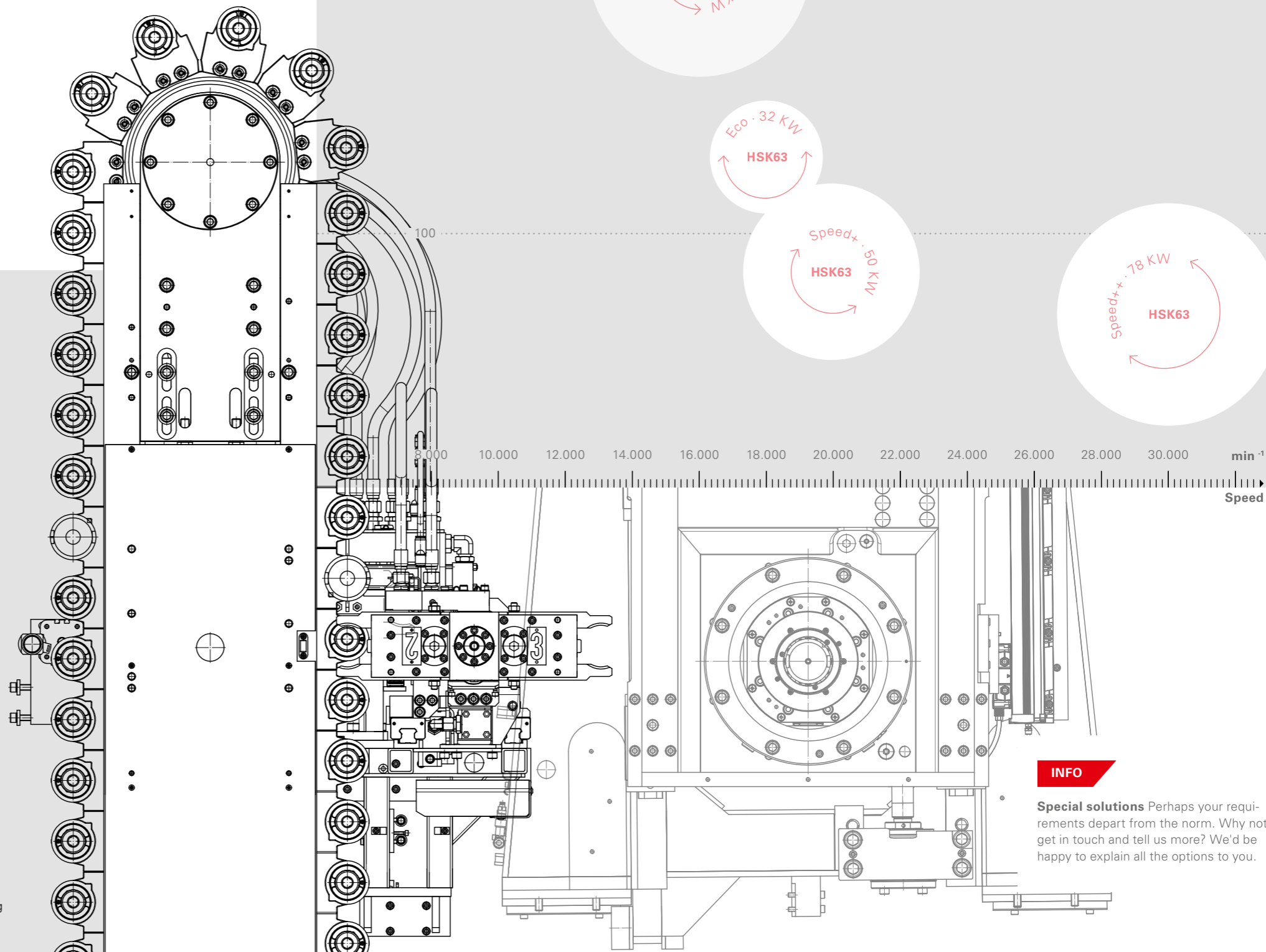
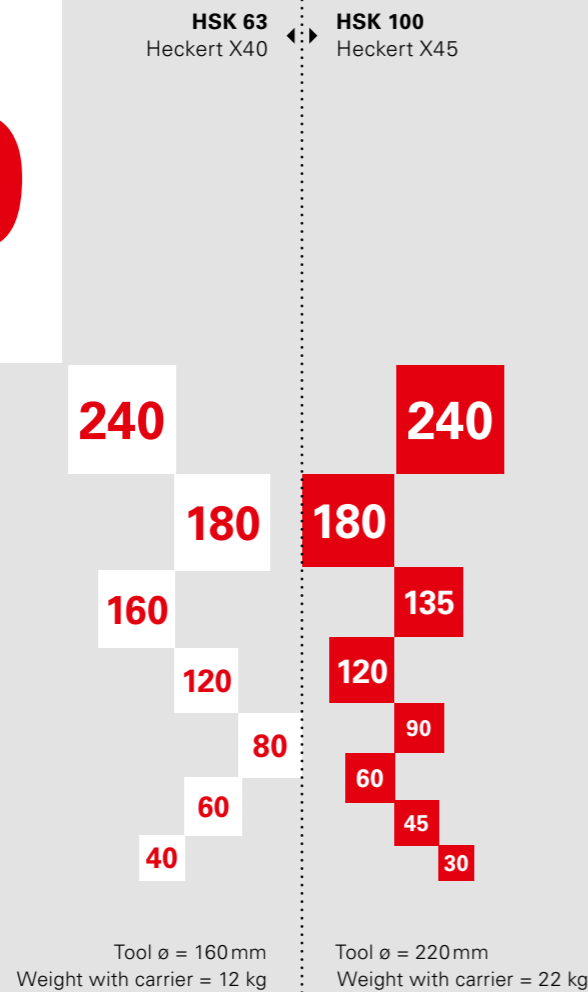

Heckert Spindles

Strong as an ox or quick as a fox – spindle properties are a number one priority when it comes to production processes. That's why we offer a wide range of spindles so that you can select the right one for your application.

INFO
Special solutions Perhaps your requirements depart from the norm. Why not get in touch and tell us more? We'd be happy to explain all the options to you.



A user's review

SAFE- GUARDING

»This machine represents a crucial step towards safeguarding the company's future.«

The Chemnitz-based **Pentzold Metallverarbeitung** faces the same challenges as many other contract manufacturers. It constantly competes with other companies for new orders, and these orders come in many different forms. They range from a batch size of one clamped directly onto the pallet, through to recurring small-series batches produced in hydraulically clamped devices, meaning that operating procedures need to be flexible and ready for any eventuality. This diversity of production requires not only user-friendly operation, but also – and most importantly – maximum precision and machine availability. This made Pentzold the ideal candidate to benefit from the many advantages of the new Heckert H50 with its fully integrated pallet storage system.

After six months of full-time use, Managing Director Holger Pentzold is happy with what he has seen: „I don't mind admitting that we found it challenging to make full use of the machine at first. But it didn't take us long to ramp things up so that we could keep the spindle constantly in action.“ Pentzold is enthusiastic about the flexibility that the company has gained, thanks in particular to the option of equipping a single machine with a mix of parts: „There are 240 slots in the tool magazine, which means we can switch seamlessly from manufacturing single parts to small-series batches. Even while the single part is still being machined, we can get on with loading two pallets in the changeover contact ready for the small-series batch. During the day shift, we work through our list and tick off the parts with complex setup requirements. We then produce small-series batches during the times that would previously have been wasted on machine setup. The late shift is generally the time when we use our new Heckert to produce the small-series parts which don't require much in the way of setup effort. The ability to run unmanned shifts is a huge win for us. Once the working day is over, we fill up the pallet storage system and the ingenious contraption continues working long after we've headed off to enjoy our evening.“

Always on our radar: user friendliness

Manufacturing solutions are growing increasingly complex, and it's becoming harder than ever to find operators who have the skills to handle them. With this in mind, our job is to simplify the operation of our machines and tailor it to your idea of what an operator should do.

The human-machine interface (HMI) is the point where a machine and its operator interact. Intuitive user guidance and clear communication are the keys to a secure manufacturing process. In the design of the HMI this was the basis - both in terms of ergonomics, interactivity and flexibility, as well as the user interface. We took the modern, intuitive operating concepts of smartphones and tablets as our starting point.

You can also choose to configure your machine with a premium-class Siemens or Fanuc control system. The systems from both of these manufacturers guarantee maximum productivity and process reliability. Of course, we equip our machines with cutting-edge fieldbus technologies for extensive diagnostic options, including the latest ASI generation in the Fanuc control systems and the future-proof Profi-Net technology with IO-Link capability in the Siemens control systems.

Like all Heckert control panels, the HMI is designed for ergonomics, operating efficiency and longevity in harsh industrial environments. This allows the HMI to be steplessly adjusted in terms of inclination and height and can be operated both in left-handed and right-handed mode. It can be folded against the machine to save space when it is not in use.



Human-machine interface (HMI)

HMI Touch Screen

The 24" high-resolution HMI touchscreen offers a wide range of configuration options. The operator can customise up to three windows with different functions or applications. These include a PDF viewer, web applications and camera applications. VNC implementations represent a simple way to integrate systems from your infrastructure, e.g. CAD/CAM applications.

Gloves are not a hurdle for our HMI. If the operator needs to wear gloves while the workpiece or tool is being handled, and still have to make entries, then our scratch-resistant touchscreen reliably takes the commands. For safe cleaning, the HMI touchscreen has a special cleaning mode.

FANUC

SIEMENS

Individual automation add-ons

They allow you to make optimum use of your machines and increase productivity. You can win back the valuable minutes previously lost on machine loading. This increases throughput and reduces production costs. You can also transport unmachined parts, finished parts and machine pallets reliably from A to B, making manual distribution of goods to individual machines a thing of the past.



Heckert pallet storage

From a technical and commercial point of view, the space-saving Heckert PS is the ideal solution for companies keen to dip their toes into the field of machine automation with workpiece changes for small and medium batch sizes.

INFO

Further details can be found in our flyer on automation solutions – or why not book a personal consultation?

Fully adaptable linear pallet storage system

Fully adaptable linear pallet storage systems are highly flexible and can be adapted to your exact requirements. A further advantage is the built-in master control station, which plans tasks and distributes them effectively to the integrated machines.

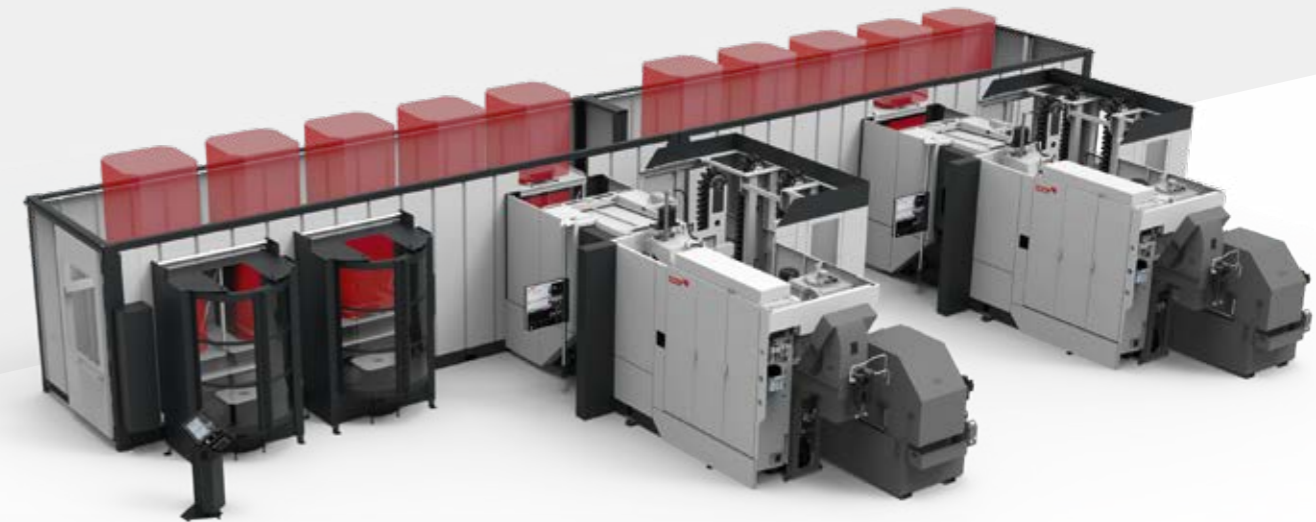

Robot cells and systems

These automation solutions lead to drastic reductions in non-productive time, particularly when handling identical workpieces and large batches.

Starrag GmbH
Otto-Schmerbach-Straße 15/17
09117 Chemnitz
Germany

T +49 371 836 22 88
F +49 371 836 23 98

sales.heckert@starrag.com
www.starrag.com

